

Forest River Presents Sunseeker



Sunseeker
2" WALL WITH BLOCK FOAM
AND SUPERLITE (R-10)

Structural integrity is not compromised at Sunseeker! Sunseeker's fully laminated walls are visibly stronger and more durable.



Competition
1.5" WALL WITH LUAN (R-6)

Sunseeker ONE-YEAR ASSISTANCE

Forest River, Inc., in affiliation with Coach-Net®, is providing one (1) year of free Roadside Assistance to all retail purchasers of new Sunseeker coaches. This is just one more way to say "Thank You" and to ensure you have an enjoyable camping experience.



- Emergency Roadside Assistance
- Nationwide Service Appointment Assistance
- Dispatch of On-site Mechanical Service
- \$2000 Trip Interruption Reimbursement
- 24-Hour Toll-Free Emergency Message Service
- Custom Trip Routing and Full Color Maps

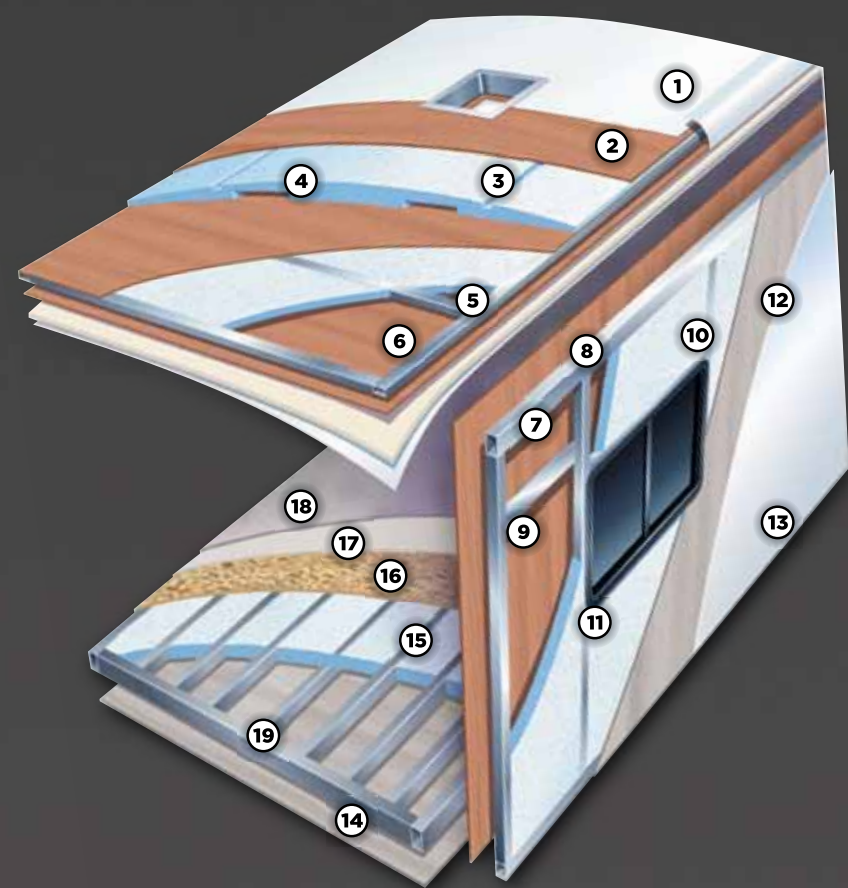

MULTI-LAYERED LAMINATED ROOF SYSTEM

1. Crowned Fiberglass Roof
2. Luan decking
3. Block Foam Insulation
4. Dual A/C Ducts
5. 1.5" Tubular Aluminum Framing
6. Soft-Touch Vinyl Ceiling

2-INCH VACUUM-BOND LAMINATED SIDEWALLS

7. 1.5" Tubular Aluminum Framing
8. Decorative Interior Wall Board
9. EGS Metal Backers
10. Block Foam Insulation
11. Openings Framed in Aluminum
12. SuperLite Composite
13. Smooth Gelcoat Fiberglass Exterior

VACUUM-BOND LAMINATED FLOOR SYSTEM

14. Fiberglass Bottom Board
15. Block Foam Insulation
16. Seamless Floor Decking
17. Beauflor Flooring (In some areas)
18. Carpet with Pad (In some areas)
19. 1.5" Aluminum Framing

Sunseeker SUPER LITE WALLS



All Sunseekers use SuperLite composite instead of a wood substrate on the sidewalls. It is lightweight, formaldehyde free and is not affected by moisture.

Sunseeker BEAUFLOF FLOORING



Beauflor: A better grade of flooring that is slip resistant even in wet conditions and highly resistant to tears. Unlike vinyl floors with paper backing, our backing remains stable in extreme hot or cold and is backed by a two-year cold crack warranty.



Sunseeker FIBERGLASS ROOF

Our fiberglass roof is extremely durable, easy to clean and will not cause black streaks like a rubber roof will.

Sunseeker DUCTED AIR WITH A "QUICK-COOL" FEATURE



All Sunseeker have ducted air and crowned fiberglass roofs to shed water. (R-18)

Quick-Cool diverts 85% of cool air to the center of the coach.

Sunseeker WATER FILTRATION



You'll appreciate the water filtration system that is standard with each Sunseeker. This compact unit filters water for the entire coach, eliminating those unwanted contaminants and odors. Insuring safe drinking water for you and your family.

Sunseeker EXCLUSIVE SERTA MATTRESS OPTIONAL



Serta is the #1 supplier to the hotel industry, just one night in a Sunseeker and you'll see why.



Sunseeker FIRESTONE RIDE-RITE

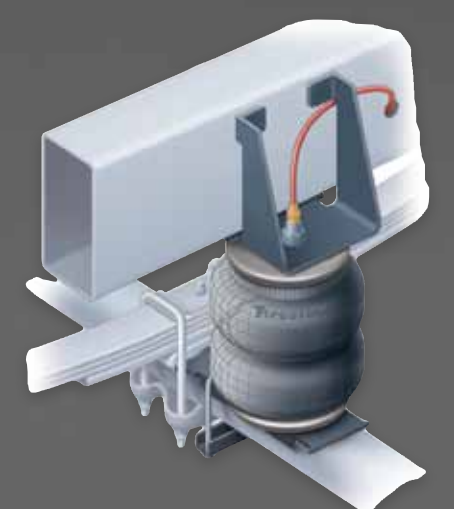

Adjustable air springs provide an improved ride and a better way to balance loads.

Sunseeker HEATED AND ENCLOSED HOLDING TANKS



The Sunseeker features a heated and enclosed utility station. Your tanks and valves are protected from mud, ice and other road debris.

Sunseeker INTEGRATED STEP



Sunseeker's entry step is integrated into the sidewall. No more slippery, or damaged power steps.

Sunseeker POWER AWNING



Extend and retract your awning with the push of a button. Both arms are adjustable to get just the right angle.

Sunseeker RESIDENTIAL DRAWER GUIDES



Full extension ball bearing drawer guides open fully for easy access to storage.

